



MR. SILENCE 30

INVERPAD TURBO POOL HEAT PUMP

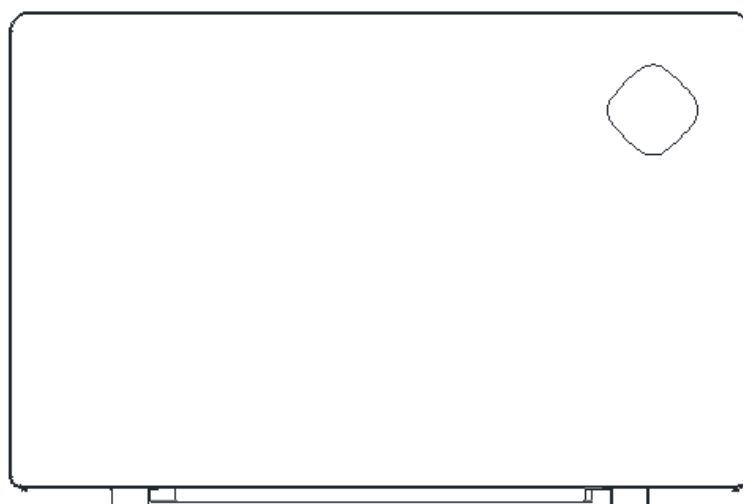

Table of contents

A. Foreword	4
B. Safety Precautions	2
1. Warning	2
2. Attention	3
3. Safety	3
C. About your heat pump	3
1. Transportation	4
2. Accessories	4
3. Features	4
4. Operating range	5
5. Introduction of different modes	5
6. Technical parameter	6
7. Dimension	8
D. Installation guidance	9
1. Installation reminder	9
2. Warning	11
3. Electric wiring diagram	11
E. Operation guidance	13
1. Key Function	13
2. Screen Display	14
3. Operation Instruction	15
F. Testing	19
1. Inspect heat pump before use	19
2. Leakage detection notice and method	19
3. Trial	19
G. Maintenance	20
H. Trouble shooting for common faults	21
I. Water pump control connection	24

A. Foreword

Thank you for choosing our inverter pool heat pump, which is designed for more silent and energy saving user experience. It is an ideal way for green pool heating.

We hope you'll enjoy using our heat pumps.

Thank you!



A2L

Warning, flammable material



Read operator's manual



Operator's manual, operating instructions



Service indicator, read technical manual

B. Safety Precautions





We have provided important safety messages in this manual and on your heat pump.
Please always read and obey all safety messages.

Environment friendly R32 Refrigerant is used for this heat pump

1. Warning



The WARNING sign denotes a hazard. It calls attention to a procedure, practice, or the like, which, if not correctly performed or adhered to, could result in personal injury or injury to a third party. These signs are rare, but are extremely important.

	a. Keep the heat pump away from fire source.
	b. It must be placed in well ventilated area; indoor or closed area is not allowed.
	c. Repair and disposal must be carried out by trained service personnel
	d. Vacuumize completely before welding. Welding can only be carried out by professional personnel in service center.

2. Attention

- a. Please read the following instructions before installation, use and maintenance.
- b. Installation must be done by professional staff only in accordance with this manual.
- c. Leakage test must be performed after installation.
- d. Except for the methods recommended by the manufacturer, do not use any methods to accelerate the defrosting process or clean the frosted parts.
- e. If a repair is required, please contact the nearest after-sales service center. The repair process must be strictly in accordance with manual. All repair practice by non-professional is prohibited.
- f. Set proper temperature in order to get comfortable water temperature to avoid overheating or overcooling.
- g. Please don't stack substances, which will block air flow near inlet or outlet area, otherwise the efficiency of the heat pump will be reduced or even stopped.
- h. Don't use or stock combustible gas or liquid such as thinners, paint and fuel to avoid fire.
- i. In order to optimize the heating effect, please install heat preservation insulation on pipes between swimming pool and the heat pump, and please use a recommended cover on the swimming pool.
- j. Connecting pipes of the swimming pool and the heat pump should be $\leq 10\text{m}$.
- k. This unit can only be installed outdoors.
- l. This unit can only be connected to a power source with a single complete cord.

3. Safety

- a. Please keep the main power supply switch far away from the children.
- b. When a power cut happens during operating, and later the power is restored, the heat pump will start up.
- c. Please switch off the main power supply in lightning and storm weather to prevent from machine damage that caused by lightning.
- d. Installation and any repairing should be conducted in the area with good ventilation. The ignition source is prohibited during the operation.
- e. Safety inspection must be carried before the maintenance or repair for heat pumps with R32 gas in order to minimize the risk.
- f. If R32 gas leaks during the installation process, all operations must be stopped immediately and call the service center.

C. About your heat pump

1. Transportation

- a. Always keep upright

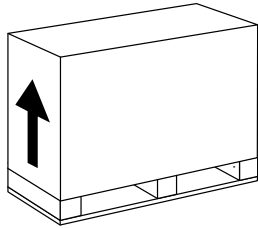

- b. Do not lift the water union
(Otherwise, the titanium heat exchanger may be damaged)

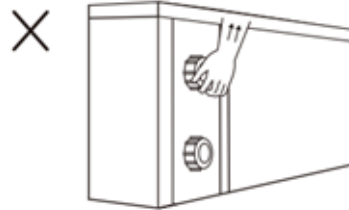

2. Accessories

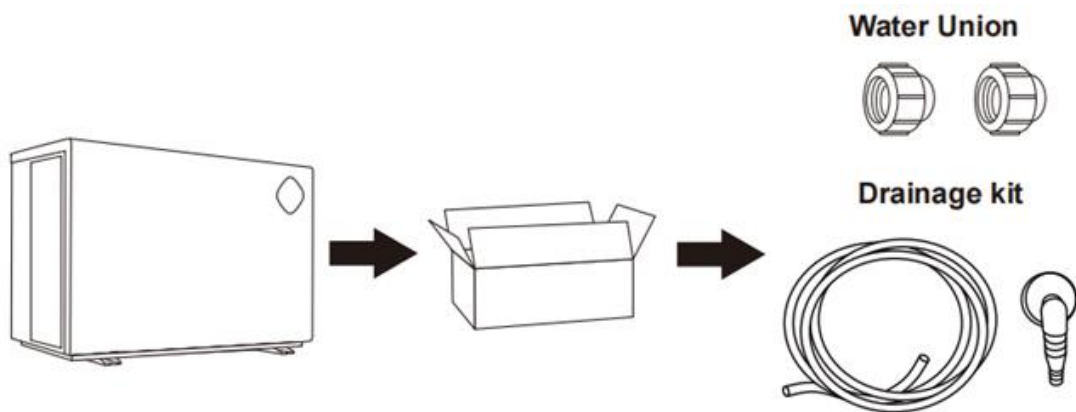

3. Features

- a. Turbo fan
- b. DC Twin-rotary inverter compressor
- c. DC Brushless fan motor
- d. EEV Technology
- e. Reverse cycle defrosting with 4-way valve
- f. High-efficiency twisted titanium heat exchanger
- g. Sensitive and accurate temp control and water temp display
- h. High pressure and low-pressure protection
- i. Full protection on electrical system



4. Operating range

To provide you comfort and pleasure, please set swimming pool water temperature efficiently and economically.

- a. The heat pump can work between air $-20^{\circ}\text{C}\sim 43^{\circ}\text{C}$,
 - b. Temperature of heating $18^{\circ}\text{C}\sim 40^{\circ}\text{C}$
 - c. Temperature of cooling $12^{\circ}\text{C}\sim 30^{\circ}\text{C}$
- Ideal operation range is between air $15^{\circ}\text{C}\sim 25^{\circ}\text{C}$.

5. Introduction of different modes

- a. The heat pump has three modes: Turbo, Perfect and Silence.
- b. They have different strengths under different conditions.

Mode	Modes	Strength
	Turbo mode	Heating capacity: 100% ~ 20% capacity Fast heating
	Perfect mode	Heating capacity: 80% ~ 20% capacity Automatic adjustment according to ambient and water temperature, intelligent optimization. High efficiency and energy saving
	Silence mode	Heating capacity: 50% ~ 20% capacity Operating at night.

6. Technical parameter

Model		MPXC1 00	MPXC1 20	MPXC1 50	MPXC1 70	MPXC1 90	MPXC23 0	MPXC28 0	MPXC28 0s	MPXC3 40	MPXC34 0s	MPXC42 0s	
Advised pool volume (m ³) *		20-35	25-45	30~55	35~65	40-75	45~80	60~90	60~90	66~110	66~110	75~120	
PERFORMANCE CONDITION: Air 27°C/ Water 27°C/ Humid. 80%													
Turbo Mode	Heating capacity (kW)	10.2	12	15	17.5	19.5	23	28	28	34	33.5	42	
Perfec t Mode	Heating capacity (kW)	7.8	9.4	11.6	13.6	15.2	18	21.6	21.6	26	26	32.5	
COP		19.5~7. 8	19.7~8. 1	20~8.1	20.4~8. 1	20~7.0	20~7.8	22~8.2	20.0~8. 0	20~7.8	19.5~8. 0	18.9~7. 8	
Average COP		14.8	14.9	14.6	15.3	14.7	14.3	14.7	14.3	14.6	14.4	14.2	
PERFORMANCE CONDITION: Air 15°C/ Water 26°C/ Humid. 70%													
Turbo Mode	Heating capacity (kW)	7.0	8.1	9.8	12	13	15	19.3	19.5	23.5	23	30	
Perfec t Mode	Heating capacity (kW)	5.5	6.6	7.8	9.5	10.9	12	15	15	18.8	18.8	23.5	
COP		7.9~5.6	8.1~5.7	8.4~5.6	9.0~5.8	7.9~5.0	9.6~6	8.9~5.7	8.3~5.6	8.0~5.7	8.0~5.6	7.8~5.5	
Average COP		7.1	7.2	7.6	7.7	7	8.1	7.6	7.4	7.1	7.1	7	
PERFORMANCE CONDITION: Air 35°C/ Water 28°C/ Humid. 80%													
Cooling capacity (kW)		4.8	5.5	6.7	9.4	10.8	11.9	13.5	13.5	15.4	15.4	20	
Operating air temperature (°C)		-20°C~43°C											
Power supply		230V 1Ph							400V 3Ph	230V 1Ph	400V 3Ph		
Rated input power (kW)		0.16~1. 35	0.18~1. 53	0.27~1. 88	0.27~2. 22	0.31~2. 6	0.31~2.7 3	0.44~3.6 4	0.45~3. 75	0.53~4. 43	0.53~4. 42	0.71~5. 88	
Input power at 50% speed (kW)		0.49	0.56	0.64	0.78	0.93	0.93	1.27	1.32	1.65	1.62	2.14	
Rated input current (A)		0.70~5. 78	0.83~6. 78	1.00~8. 17	1.13~9. 43	1.35~1 1.3	1.39~11. 65	1.87~15. 48	0.64~5. 26	2.26~1 9.0	0.77~6. 45	1.01~8. 41	
Sound level at 1m dB(A)		36.0~4 1.8	36.0~4 2.5	36.3~4 3.9	37.2~4 5.5	37.5~4 6.0	37.6~46. 8	37.9~48. 2	38.0~48 .4	38.2~4 8.7	38.3~48 .8	38.8~49 .3	

Sound level 50% at 1m dB(A)	36.4	36.5	38.4	40.3	40.5	41	41.2	41.6	43	43.2	43.6
Sound level at 10 m dB(A)	16.0~2 1.8	16.0~2 2.5	16.3~2 3.9	17.3~2 5.5	17.5~2 6.0	17.6~26. 8	17.9~28. 2	18.0~28 .4	18.2~2 8.7	18.3~28 .8	18.8~29 .3
Advised water flux (m ³ /h)	2~4	2~4	3~4	4~6	5~7	6~9	8~10	8~10	10~12	10~12	12~18
Water connection (mm)	50mm										

Remarks:

This heat pump is able to perform normal within air temp -20°C~+43°C, efficiency will not be guaranteed out of this range. Please take into consideration that the pool heat pump performance and parameters are different under various conditions. Related parameters are subject to adjustment periodically for technical improvement without further notice. For details, please refer to nameplate.

7. Dimension

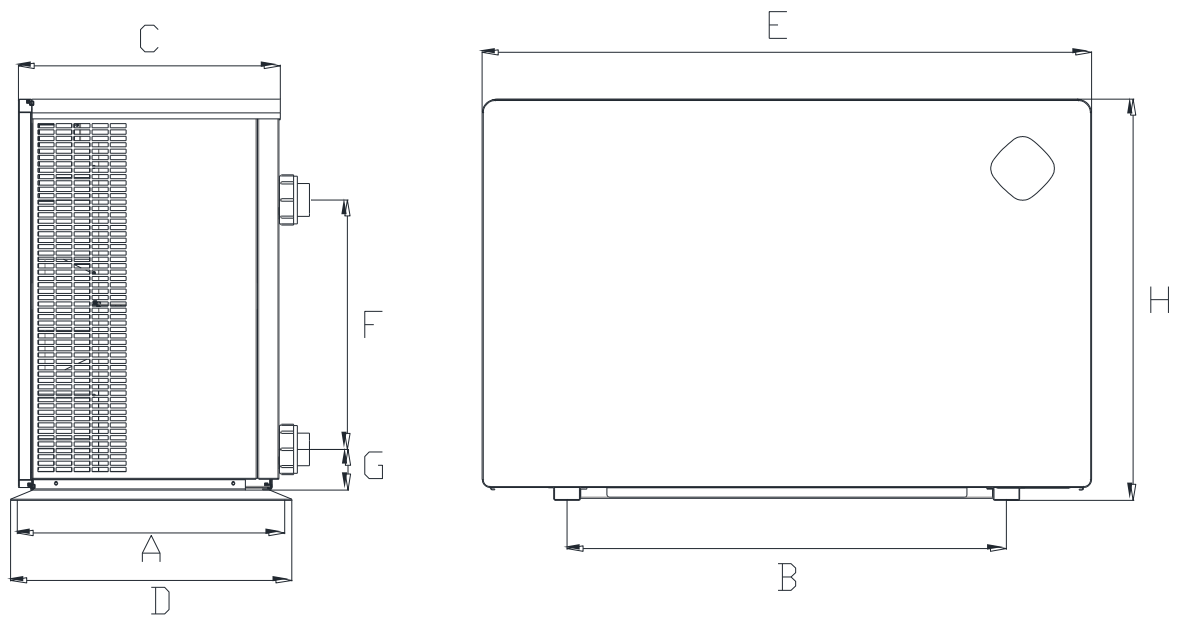

Size(mm) / Name / Model	A	B	C	D	E	F	G	H
MPXC100	505	616	494	530	936	300	77	655
MPXC120	505	616	494	530	936	300	77	655
MPXC150	505	616	494	530	936	340	77	655
MPXC170	505	715	494	530	1036	370	77	655
MPXC190	505	715	494	530	1036	380	77	655
MPXC230	505	784	494	530	1104	470	77	757
MPXC280	505	808	514	545	1129	550	75	945
MPXC280s	505	808	514	545	1129	550	75	945
MPXC340	520	939	514	545	1310	570	75	945
MPXC340s	520	939	514	545	1310	570	75	945
MPXC420s	520	994	514	545	1405	670	75	1070

※Above data is subject to modification without notice.

Note: Above swimming pool heat pump specification drawing is for installation reference only to technical staff.

D. Installation guidance

1. Installation reminder

Only a professional staff is allowed to install the heat pump. The users are not qualified to install by themselves, otherwise the heat pump might be damaged and risky for users' safety.

a. Installation distance, drainpipe installation and water pipe connection

 The inverter pool heat pump should be installed in a good ventilation place. The distance should be greater than following;

Installation distance

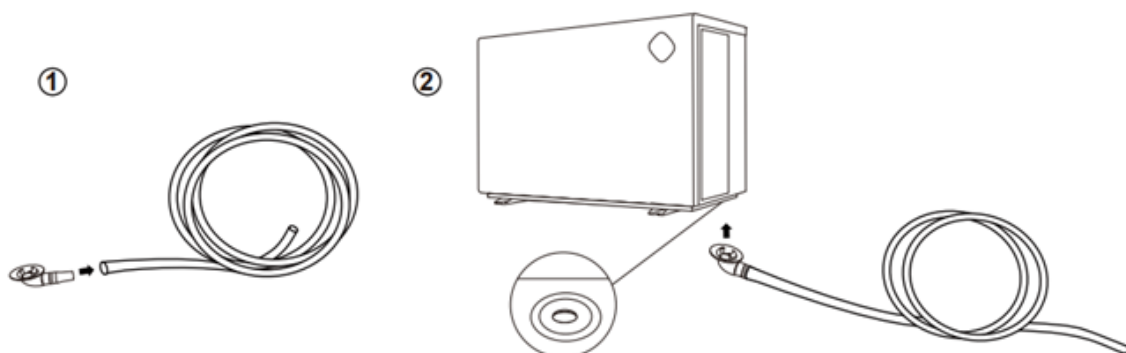
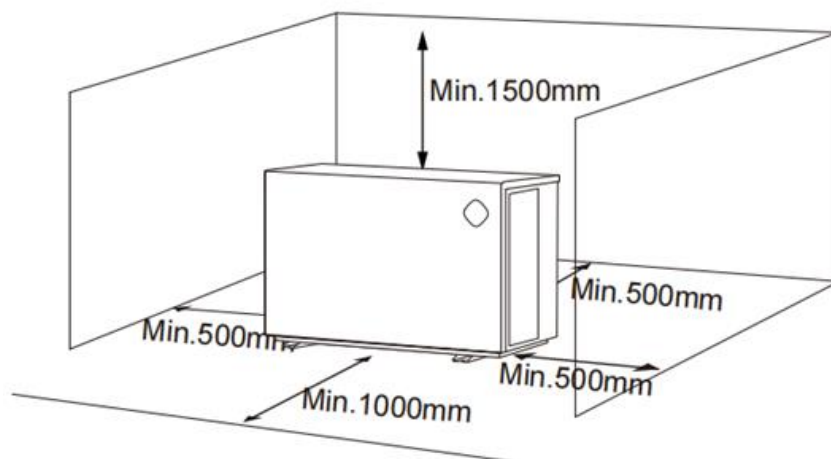

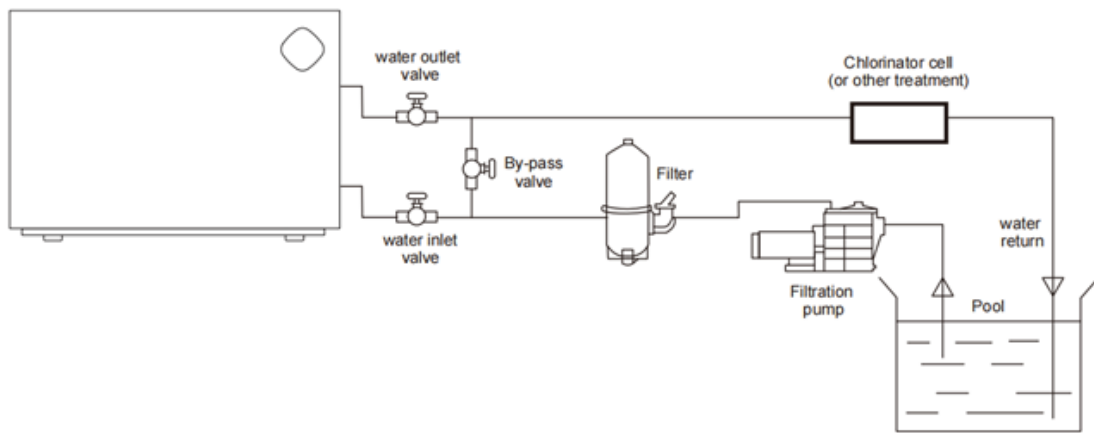



- 1) The frame must be fixed by bolts (M10) to concrete foundation or brackets. The concrete foundation must be solid and fastened; the bracket must be strong enough and antirust treated;
- 2) Please don't stack substances that will block air flow near inlet or outlet area, and there is no barrier within 50cm behind the machine, or it will affect the efficiency of the heat pump and even stop the machine;
- 3) The machine needs an appended pump (Supplied by the user). The recommended pump specification-flux: refer to Technical Parameter, Max lift $\geq 10\text{m}$;
- 4) When the machine is running, there will be condensation water discharged from the bottom, please pay attention to it. Please hold the drainage nozzle (accessory) into the hole and clip it well, and then connect a pipe to drain the condensation water out.

b. Water pipe connection

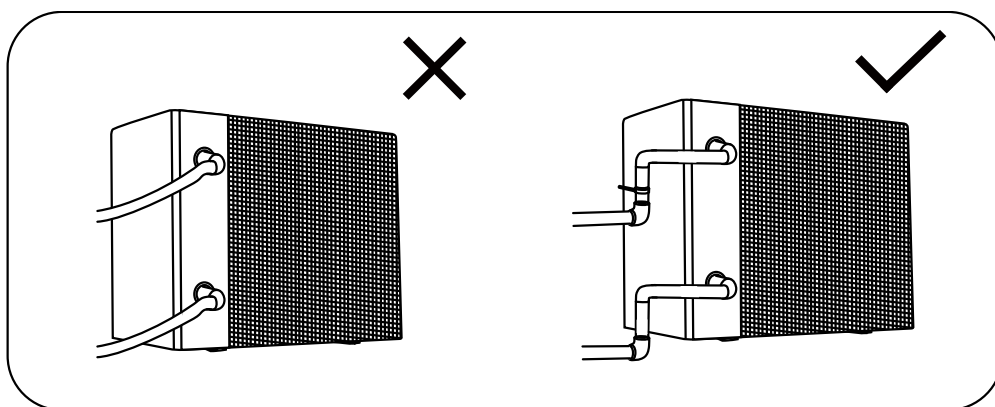
 The inlet and outlet water unions can't stand the weight of soft pipes. The heat pump must be connected by hard pipes!



 DO NOT install water pipes in a way that they pass behind the heat pump's evaporator. In case this cannot be avoided, cover the pipes with thermal insulation foam.

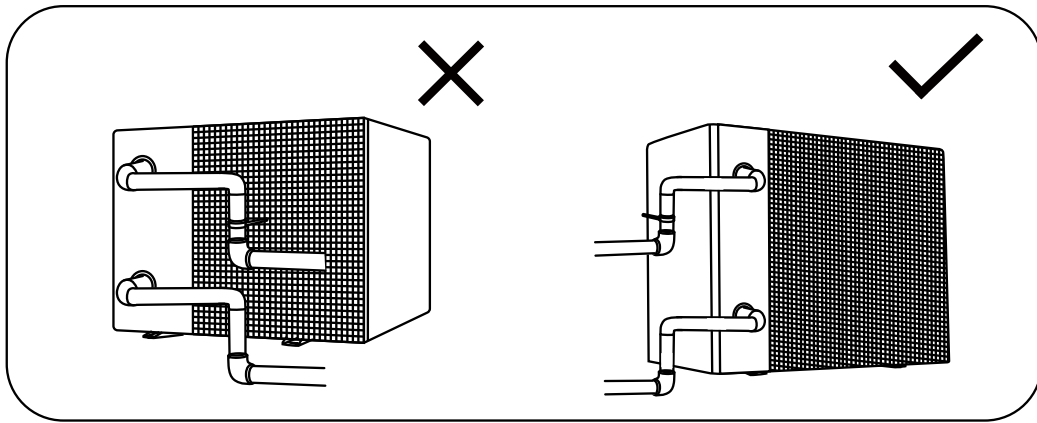

2. Warning

- Connect to appropriate power supply, the voltage should comply with the rated voltage of the products.
- Earth the machine well.
- Wiring must be handled by a professional technician according to the circuit diagram.
- Set leakage protector according to the local code for wiring (leakage operating current $\leq 30\text{mA}$).
- The layout of power cable and signal cable should be orderly and not affecting each other; the cross-sectional area of the cables can be appropriately enlarged according to the environmental conditions (such as ambient temperature, direct sunlight, rainfall, network voltage, cable length)

3. Electric wiring diagram

a. For power supply: 230V 50Hz

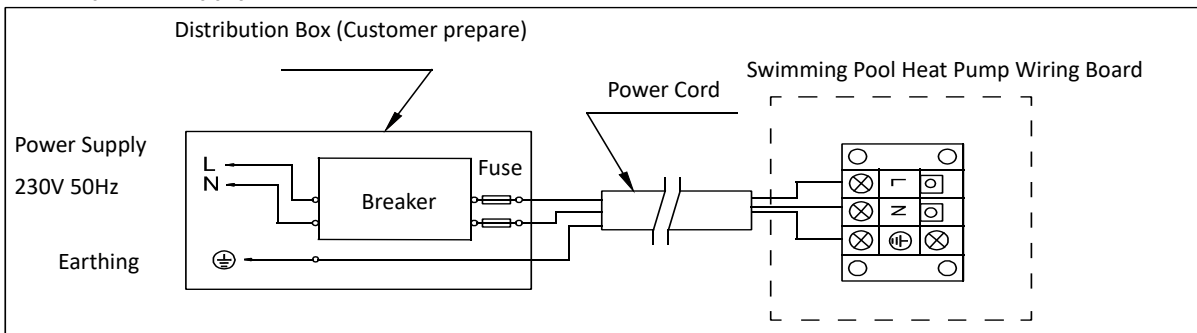

b. For power supply: 400V 50Hz

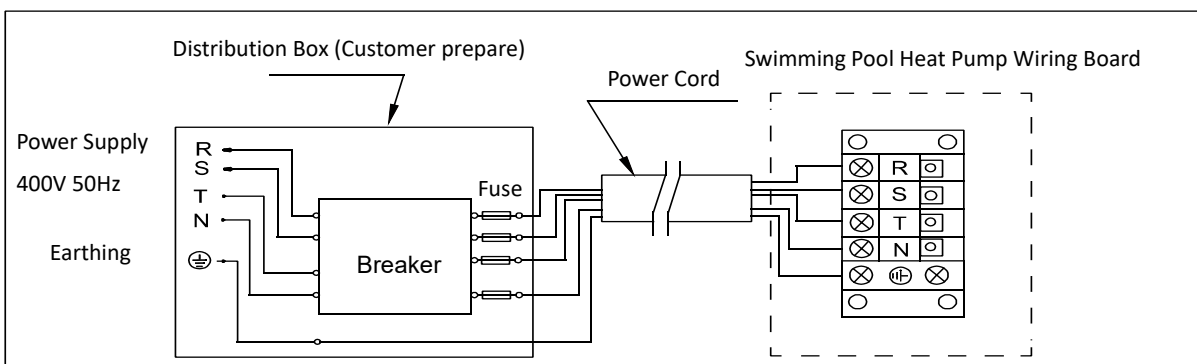

Note:



- 1) Must be hard wired, plug is not allowed.
- 2) The swimming pool heat pump must be earthed well.

4. References for protecting devices and cable specification

MODEL		MPXC1 00	MPXC1 20	MPXC1 50	MPXC1 70	MPXC1 90	MPXC2 30	MPXC2 80	MPXC3 40	MPXC34 0s	MPXC42 0s
Breaker	Rated Current (A)	11	12	15	19	20	22.5	24.5	30	11.3	15
	Rated Residual Action Current (mA)	30	30	30	30	30	30	30	30	30	30
Fuse (A)		11	12	15	19	20	22.5	24.5	30	11.3	15
Power Cord (mm ²)		3×1.5	3×2.5	3×2.5	3×2.5	3×2.5	3×4	3×4	3×4	5×2.5	5×2.5
Signal cable (mm ²)		3×0.5	3×0.5	3×0.5	3×0.5	3×0.5	3×0.5	3×0.5	3×0.5	3×0.5	3×0.5
Maximum Current (A)		9	10	12.5	16	16.5	18.5	20.5	24	9.4	12.5











※ Above data is subject to modification without notice.

Note: Above data is adapted to power cord < 10m. If power cord is 10m ~ 40m, the wire diameter must be increased. The signal cable can be extended to 50m maximum.

E. Operation guidance

1. Key Function



Symbol	Heating only mode	Heating & cooling modes
	<ol style="list-style-type: none"> 1. Power On/Off 2. Wi-Fi setting 	<ol style="list-style-type: none"> 1. Power On/Off 2. Wi-Fi setting
	Lock/Unlock screen	<ol style="list-style-type: none"> 1. Lock/Unlock Screen 2. Heating mode (18-40°C) 3. Cooling mode (12-30°C) 4. Auto mode (12-40°C)
	<ol style="list-style-type: none"> 1. Turbo  2. Perfect  3. Silence  	<ol style="list-style-type: none"> 1. Turbo  2. Perfect  3. Silence 
 	<ol style="list-style-type: none"> 1. Temperature Setting 	<ol style="list-style-type: none"> 1. Temperature Setting

Attention:

- i. The controller has power-down memory function.
- ii. The buttons will turn dark when it's locked.

2. Screen Display

a. Plugged without turning on



b. Power on







Heating& cooling

Turbo, Perfect &
Silence display

Inlet water temperature
display

Outlet water
temperature display



	Heating mode	
	Cooling mode	
	Auto mode	
 8.8.8 % kW	Input power/ Running speed percentage	
	Wi-Fi connection	
	Inlet	
	Outlet	

3. Operation Instruction

a. Screen Lock

- 1) There is automatic screen lock function. No operation for more than 30 seconds, screen will automatically lock, and screen will dim while the lock button will light on, and other button light will be off.







- 2) Press “” for 3 seconds to unlock the screen; screen and buttons will light on.



- 3) Press “” for 3 seconds to lock the screen; screen will be dark; lock button lights on and other buttons will light off.





- 4) Only “” works under off-screen; other buttons work after screen on.

- 5) Lock Period: only “” lights on. If with Wi-Fi, “” and “” light on.

b. Power On



Press “” for 3 seconds to unlock screen. Press “” to power on machine.







c. Temperature Setting





Press “” and “” to display and set temperature under screen on.

d. Mode Selection

- 1) Heating/Cooling/Auto

Press “” to switch among heating “”, cooling “” and auto mode “”.

1) Heating mode “”: Water temperature setting range(18-40°C)





2) Cooling mode “”: Water temperature setting range(12~30°C)



3) Auto mode “”: Water temperature setting range(12~40°C)

* When water inlet temperature is higher than setting point, automatic cooling mode starts.

* When water inlet temperature is lower than setting point, automatic heating mode starts.



e. Turbo/Perfect/ Silence mode

Heating mode: Press “” to switch among Turbo mode , Perfect mode  and Silence mode .

Cooling and Auto mode: only support Turbo mode , Perfect mode .

f. Operating frequency



Switching between real-time input power and compressor speed percentage display: Real-time input power is displayed

by default. With the controller unlocked, press and hold the “” and “” keys for 5 seconds to switch the display of real-time input power and compressor speed percentage.





g. Wi-Fi

1) Wi-Fi connection

When the screen is on, press “” for 3 seconds, after “” flashing, enter Wi-Fi connection. Connect Wi-Fi on mobile phone and input password, and then control equipment by Wi-Fi. When APP connects Wi-Fi successfully, “” lights on.



2) WIFI reset (WIFI password change or the network configuration change)

Press “” for 10 seconds, after “” slowly flashing for 60s, and lights off. Clear configuration records and repeat step 1).

3) “” will always on after connection.

h. Defrosting

- 1) Automatic defrosting: When machine is auto defrosting,  will flash, and return to previous working mode when it finishes.
- 2) Manual Defrosting: To enter forced defrosting mode, the compressor must be working more than 10 minutes. In

heating mode, press “” and “” on touch controller simultaneously for 5 seconds to start forced defrosting.



(Remarks: the interval between each manual defrosting should be more than 35 minutes.)

Operation and exit condition of Automatic and Manual defrosting is same.

i. Advanced applications (Professional operation)

1) Running Status Checking

Press “” for 5 seconds to enter running status checking. During this time, the display will show the status symbol

“C0” and its corresponding value. Change status through “” and “” to check corresponding value. Press



“” to quit “Running Status Checking”.

Running status checking table:

Symbol	Content	Unit
C0	Inlet water temp	°C

C1	Outlet water temp	°C
C2	Ambient temp	°C
C3	Exhaust gas temp	°C
C4	Evaporator coil pipe temp	°C
C5	Return gas temp	°C
C6	Cooling coil pipe temp	°C
C9	Cooling plate temp	°C
C10	EEV opening angle	P
C11	DC motor fan speed	r/min

j. Temperature display conversion (Celsius/Fahrenheit)

When the screen is on, Press “” and “” simultaneously for 5 seconds to switch the display between degrees Celsius and degrees Fahrenheit.

Attention: The controller has power-down memory function.

F. Testing

1. Inspect heat pump before use

- a. The ventilating device and outlets are operating adequately and are not obstructed.
- b. It's prohibited to install refrigeration pipe or components in corrosive environment.
- c. Inspect the electric wiring on basis of the electric wiring diagram and earthing connection.
- d. Double confirm the main machine power switch should be off.
- e. Check temperature setting.
- f. Inspect the air inlet and outlet.

2. Leakage detection notice and method



- a. Leakage checking is prohibited in closed area.
- b. The ignition source is prohibited during the leakage inspection. A halide torch (or any other detector using a naked flame) shall not be used.
- c. Leakage detection fluids can be applied with most refrigerants but the use of detergents containing chlorine shall be avoided as the chlorine may react with the refrigerant and corrode the copper pipe.
- d. Vacuumize completely before welding. Welding can only be carried out by professional personnel in service center.
- e. Please stop using while gas leakage occurs, and contact professional personnel in service center.

3. Trial

- a. The user must "Start the Pump before the Machine, and Turn off the Machine before the Pump", or the machine will be damaged.
- b. Before start the heat pump, please check for any leakage of water and set the appropriate temperature, then switch on the power.
- c. In order to protect the swimming pool heat pump, the machine is equipped with a time lag starting function, the fan will run 1 minute earlier than the compressor when starting the machine, and it will stop running 1 minute later than the compressor when power off the machine.
- d. After the swimming pool heat pump start up, please kindly checking for any abnormal noise from the machine.

G. Maintenance



“CUT OFF” power supply of the heat pump before cleaning, examination and repairing

1. In winter season when you don't swim:
 - a. Cut off power supply to prevent any machine damage.
 - b. Drain water clear of the machine, when using the machine at ambient temperatures below 2°C, please keeping the water flowing.
 - d. Before covering the machine with winter cover, please make sure all water on the surface of the heat pump has been wiped and clean.
 - c. Cover the machine body when not in use.

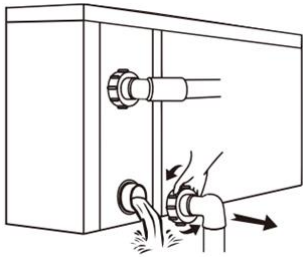

!!!Important:

Unscrew the water nozzle of inlet pipe to let the water flow out.

When the water in machine freezes in winter season, the titanium heat exchanger may be damaged.

2. Please clean this machine with household detergents or clean water, NEVER use gasoline, thinners, or any similar fuel.
3. Check bolts, cables, and connections regularly.
4. If repair or scrap is required, please contact authorized service center nearby.
5. Do not attempt to work on the equipment by yourself. Improper operation may cause danger.
6. In case of risk, safety inspection must be carried before the maintenance or repairing for heat pumps with R32 gas.

H. Trouble shooting for common faults

1. Repairing Guidance



WARNING:

- a. If repair or scrap is required, please contact authorized service center nearby.
- b. Requirements for Service Personnel
- c. Any person who is involved with working on or breaking into a refrigerant circuit should hold a current valid certificate from an industry-accredited assessment authority, which authorizes their competence to handle refrigerants safely in accordance with an industry recognized assessment specification.
- d. Do not attempt to work on the equipment by yourself. Improper operation may cause danger.
- e. Strictly comply with the manufacturer's requirements when charging R32 gas and equipment maintenance. This chapter focuses on special maintenance requirements for swimming pool heat pump with R32 gas. Please refer to the technical service manual for detailed maintenance operation.
- f. Vacuumize completely before welding. Welding can only be carried out by professional personnel in service center.

2. Failure solution and code

Failure	Reason	Solution
When powered on, the controller displays a code	Startup code	This is normal. Please wait until it disappears.
Unresponsive controller	Some models have screen lock function.	Refer to the manual to unlock the screen
Heat pump doesn't run	Improper operation	Refer to the manual
	No power	Wait until the power recovers
	Unit is powered off	Switch on the power
	Burned fuse	Check and change the fuse
	The breaker is off	Check and turn on the breaker
	Voltage anomaly	Inspection by professional
Unit suddenly starts or stops running	The unit may be in defrost. At this point the fan stops spinning and the heat indicator on the controller will flash	Not failure, the unit will switch back after defrosting
	Some models have a timed power on/off function.	Refer to the manual to disable this function
	Once the set temperature is reached, the heat pump will go into standby	This is normal
Air is blowing out, but unit is not heating well	Evaporator blocked	Clear the blockage
	Air inlet and/or outlet blocked	Clear the blockage
	3 minutes start delay protection for compressor	Wait patiently
Display normal, but no heating	Set temperature too low	Set to proper temperature
	3 minutes start delay protection for compressor	Wait patiently
Unit is releasing white smoke	The unit is defrosting	This is normal. Please wait until unit finished defrosting.
Unit is leaking water	In heating mode, condensation will be generated on the evaporator and released through the bottom of the unit	This is normal
If above solutions don't work, please contact your installer with detailed information and your model number. Don't try to repair it yourself.		

Note: If the following conditions happen, please stop the machine immediately, and cut off the power supply immediately.

Then contact your dealer:

1. Unit has stopped running because of external factors
2. The fuse is frequently broken or leakage circuit breaker jumped.

Protection & Failure code

NO.	Display	Protection code description
1	E3	No water protection
2	E5	Power supply excesses operation range (not failure)
3	E6	Excessive temp difference between inlet and outlet water(Insufficient water flow protection)
4	Eb	Ambient temperature too high or too low protection (not failure)
5	Ed	Anti-freezing reminder (not failure)
NO.	Display	Failure code description
1	E1	High pressure protection
2	E2	Low pressure protection
3	E4	3 phase sequence protection (three phase only)
4	E7	Water outlet temp too high or too low protection
5	E8	High exhaust temp protection
6	EA	Heat exchanger overheat protection/Evaporator overheat protection (only at cooling mode)
7	P0	Controller communication failure
8	P1	Water inlet temp sensor failure
9	P2	Water outlet temp sensor failure
10	P3	Gas exhaust temp sensor failure
11	P4	Evaporator coil pipe temp sensor failure
12	P5	Gas return temp sensor failure
13	P6	Cooling coil pipe temp sensor failure
14	P7	Ambient temp sensor failure
15	P8	Cooling plate temp. sensor failure
16	P9	Current sensor failure
17	PA	Restart memory failure
18	F1	Compressor driver module failure
19	F2	PFC module failure
20	F3	Compressor start failure
21	F4	Compressor running failure
22	F5	Inverter board over current protection
23	F6	Inverter board overheat protection
24	F7	Current protection
25	F8	Cooling plate overheat protection
26	F9	Fan motor failure
27	Fb	Power filter plate No-power protection
28	FA	PFC module over current protection

I. Water pump control connection

Water pump: 230V voltage, $\leq 500W$ capacity

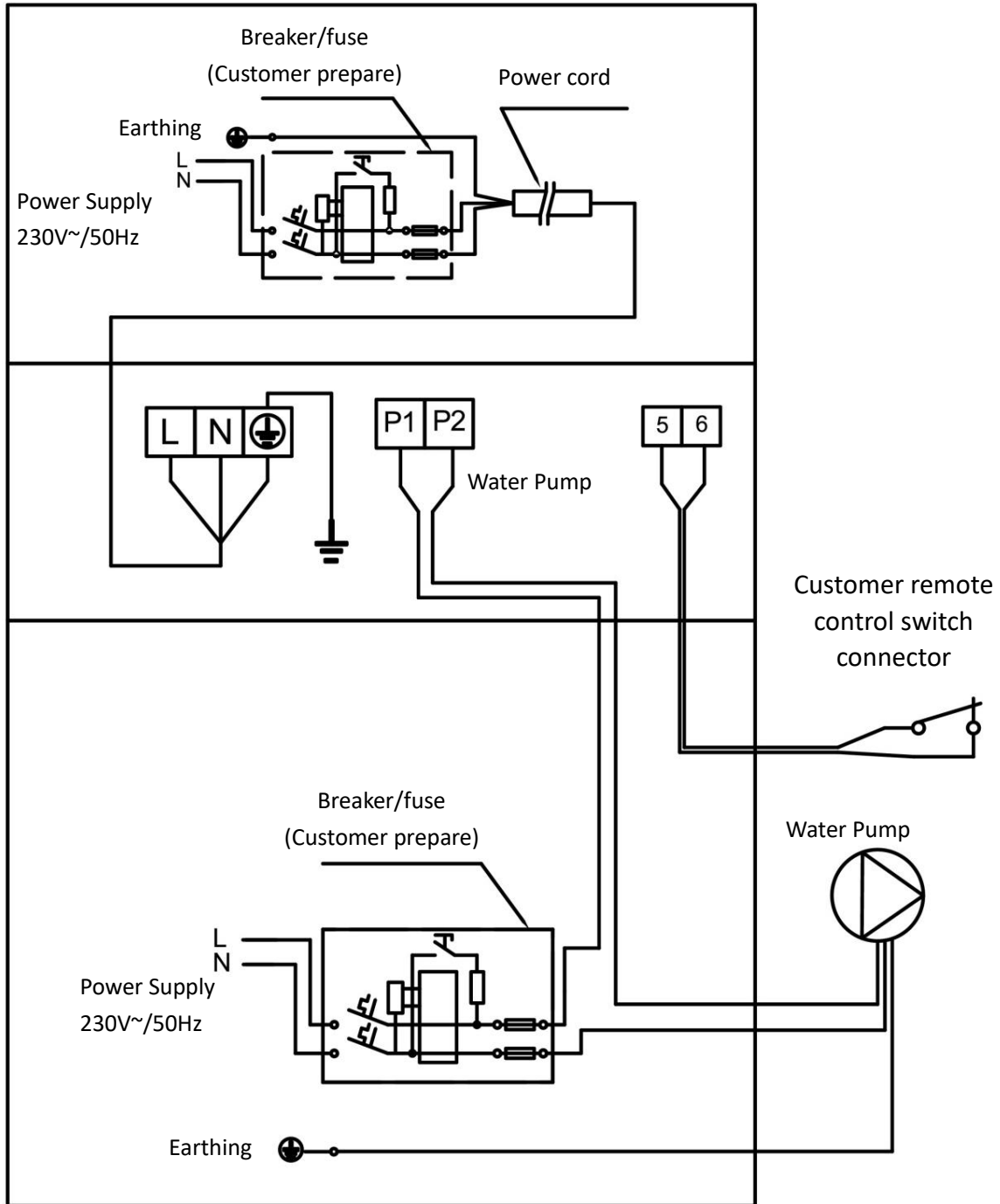

Water pump: 230V voltage, >500W capacity

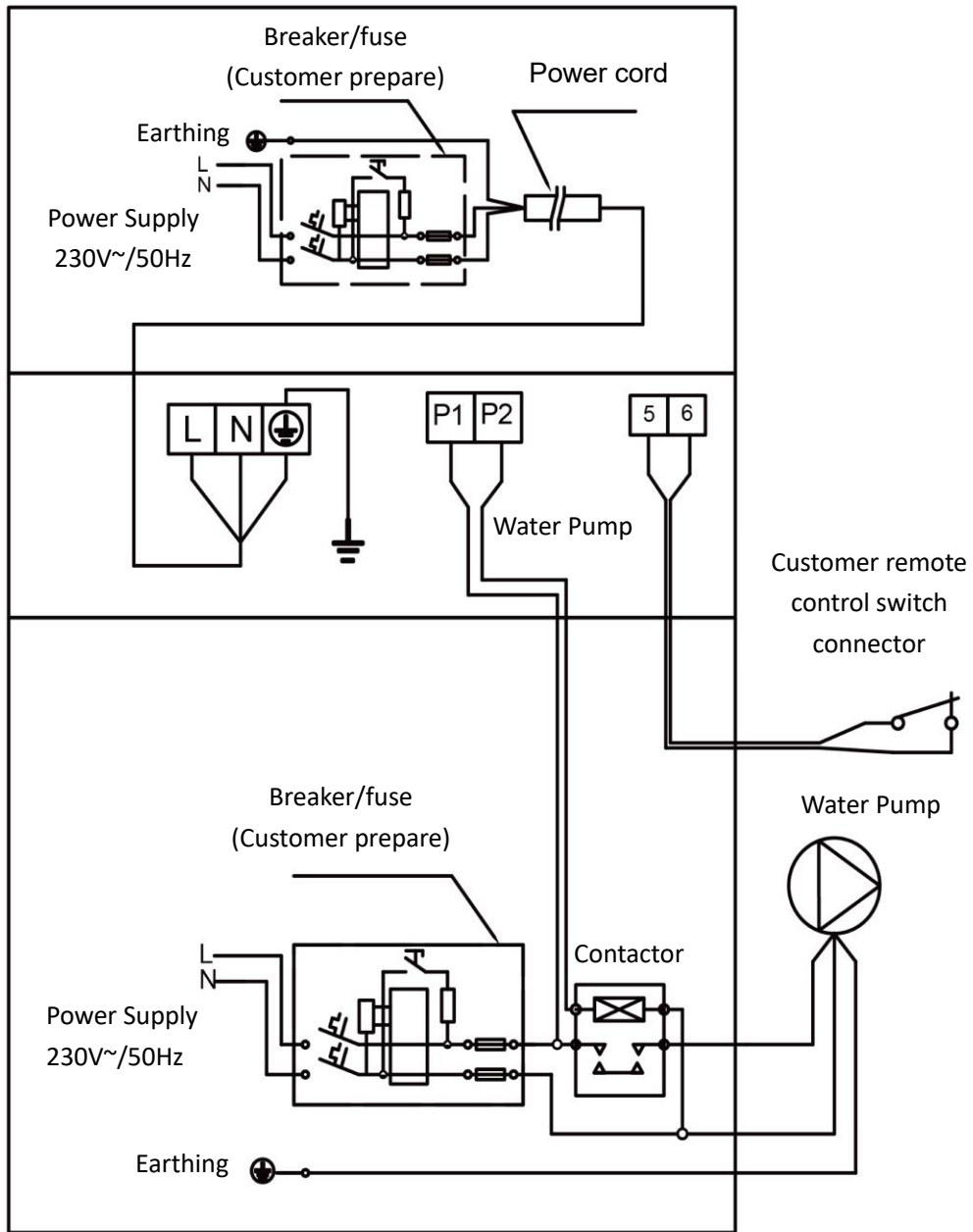

Water pump: 400V voltage

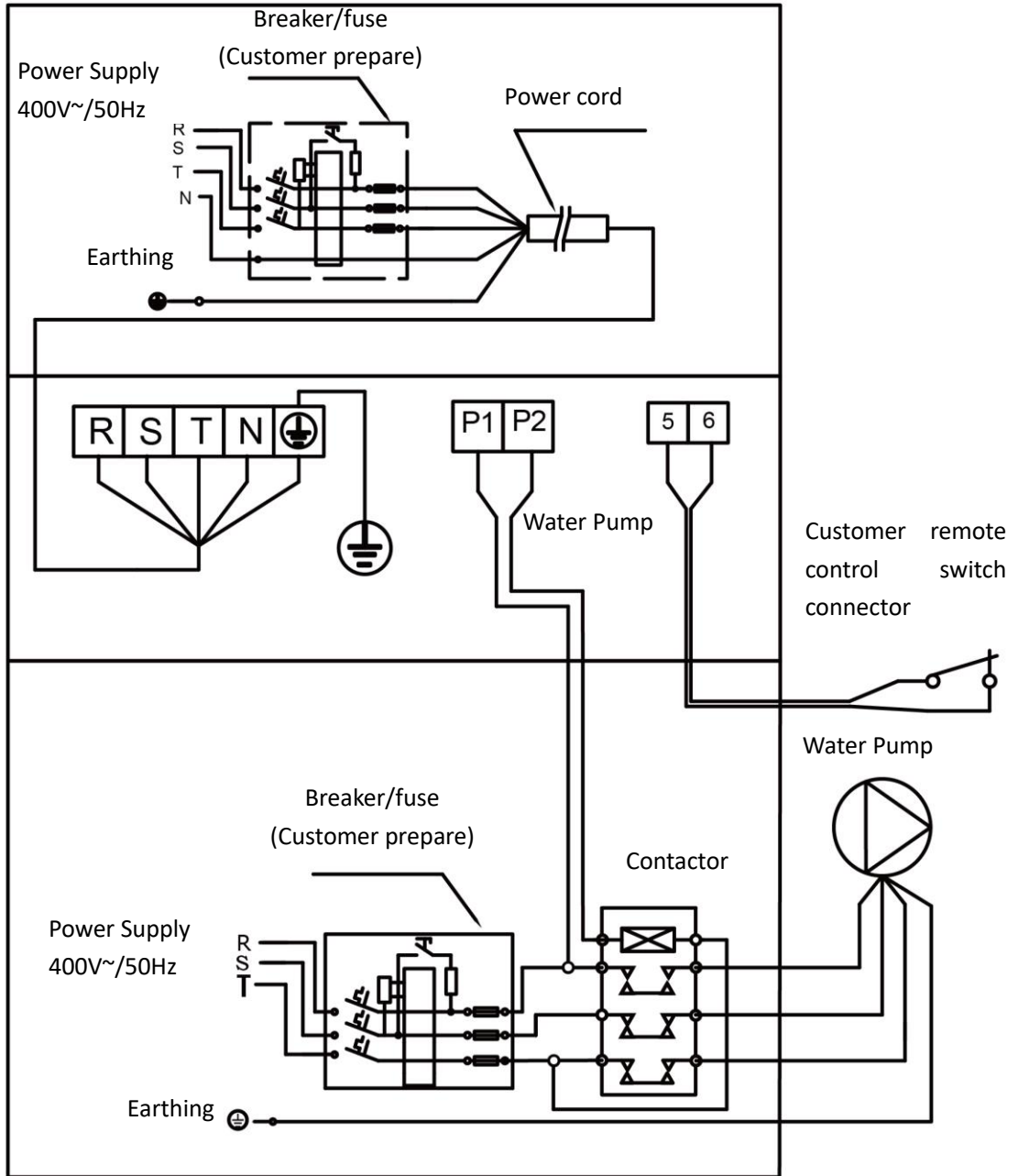

Water pump control and timer connection

1: Water pump timer

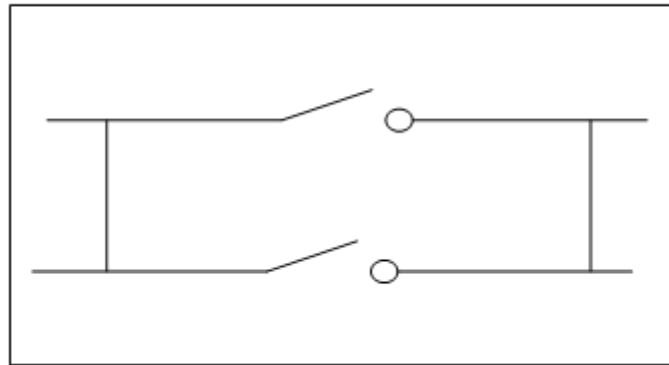

2: Water pump wiring of Heat Pump

Note: The installer should connect 1 parallel with 2 (as above picture). To start the water pump, condition 1 or 2 is connected. To stop the water pump, both 1 and 2 should be disconnected.

J. Wi-Fi operation

① InverGo Download



Android



iOS



② Account Registration

Register by e-mail or third-party application.

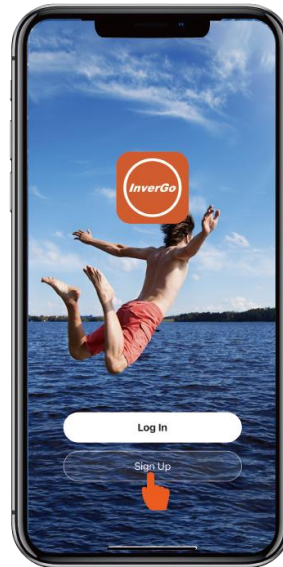

a. E-mail registration.

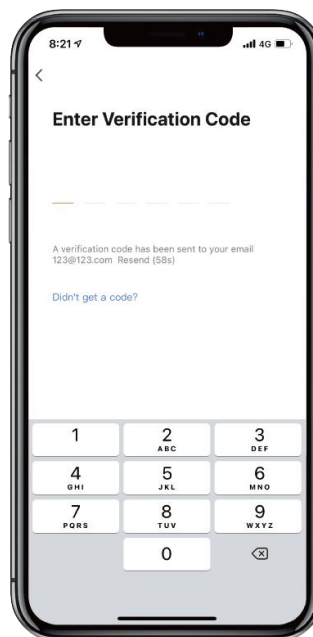
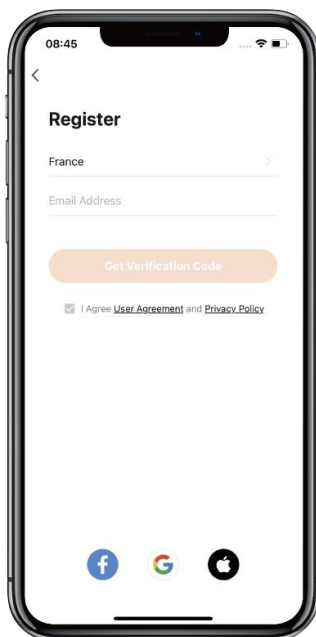

b. Register through third-party application

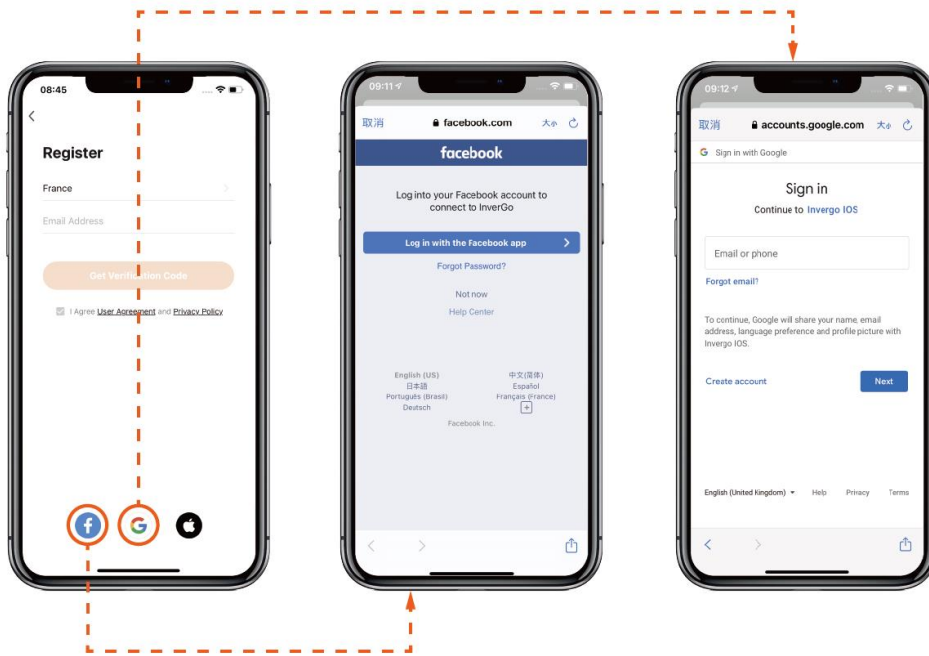

3 Create Family

Please set family name and choose location of device.

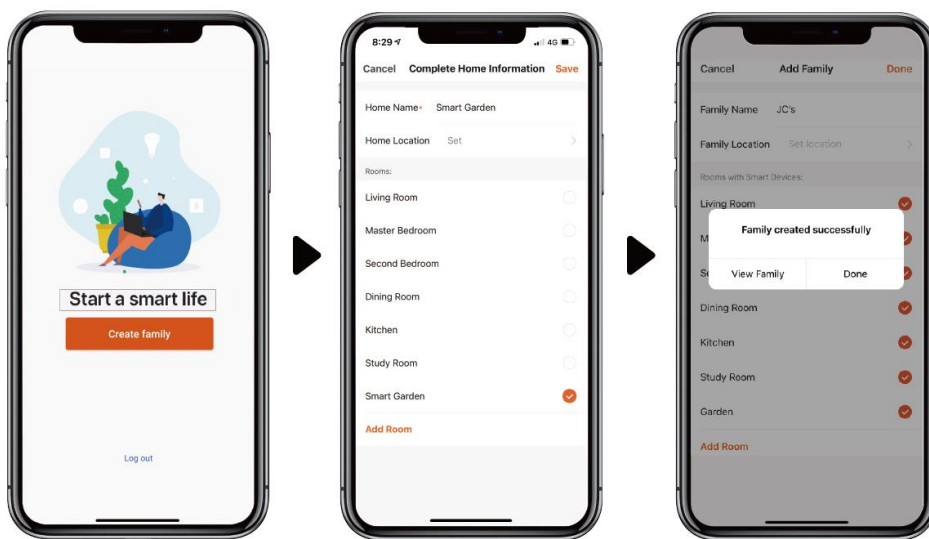

4 APP Pairing

a. With Bluetooth

1. Please confirm that you're connected to Wi-Fi and your Bluetooth is on.
2. Click "Add Device", and then follow the instructions to pair device.

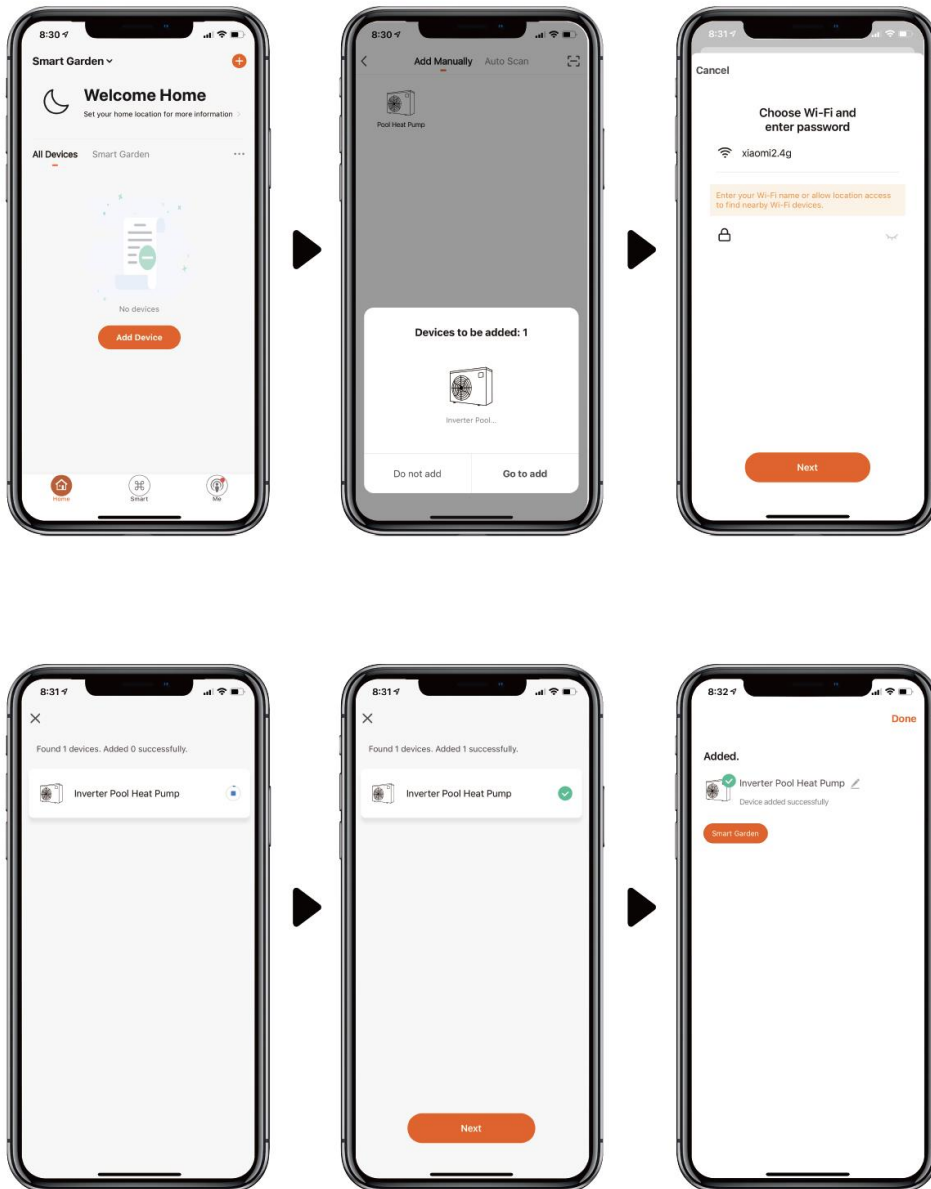

b. With Wi-Fi

1. Please make sure you are connected to Wi-Fi.

2. Press "📶" for 3 seconds to unlock the screen. Press "🔌" for 3 seconds and release. After hearing "Beep", enter Wi-Fi password in app. During connection, "📶" will flash. Once the app connects to Wi-Fi successfully, "📶" will display.



3. Click "Add Device", and then follow the instructions to pair device.

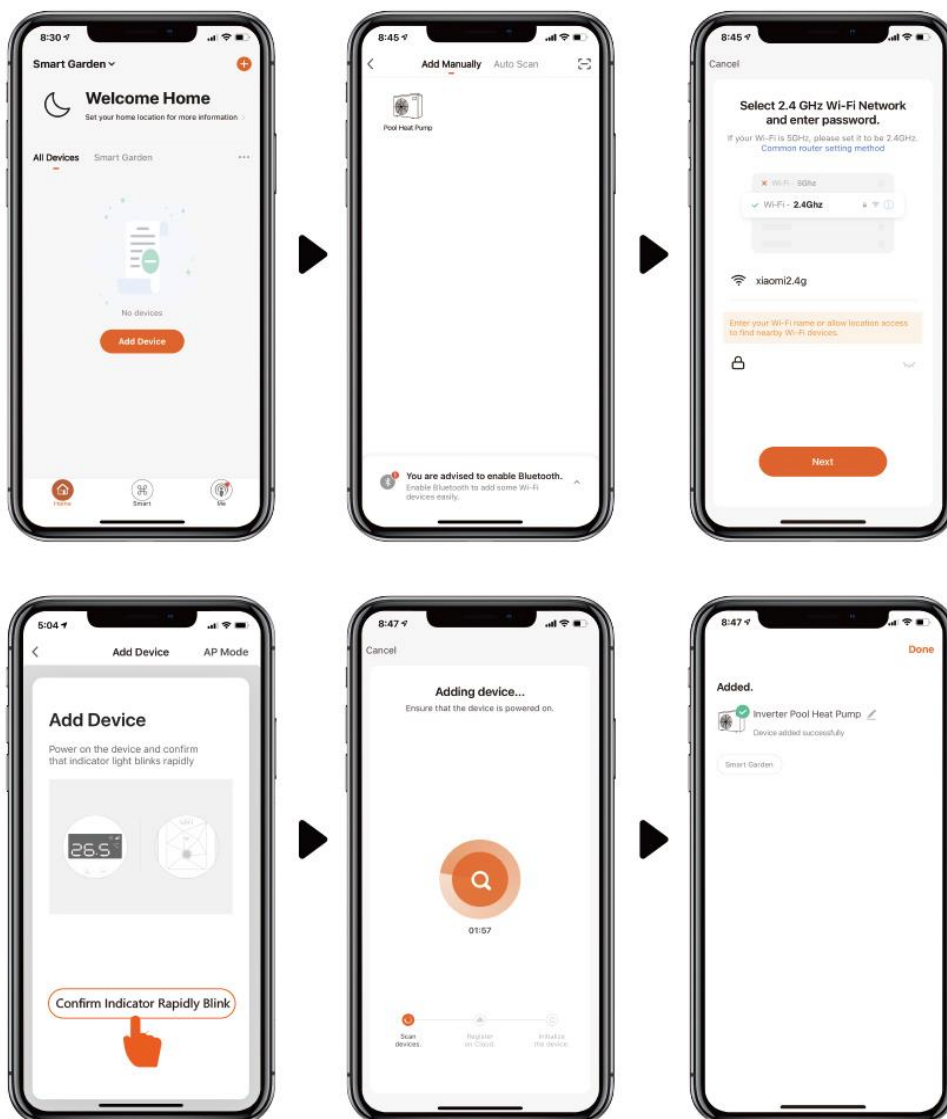

5 Operation

1. For heat pump with Heating function only:



2. For heat pump with Heating & Cooling function:



6 Share Devices to Your Family Members

After pairing, if your family members also want to control the device, please let your family members register “InverGo” first, and then the administrator can operate as below:

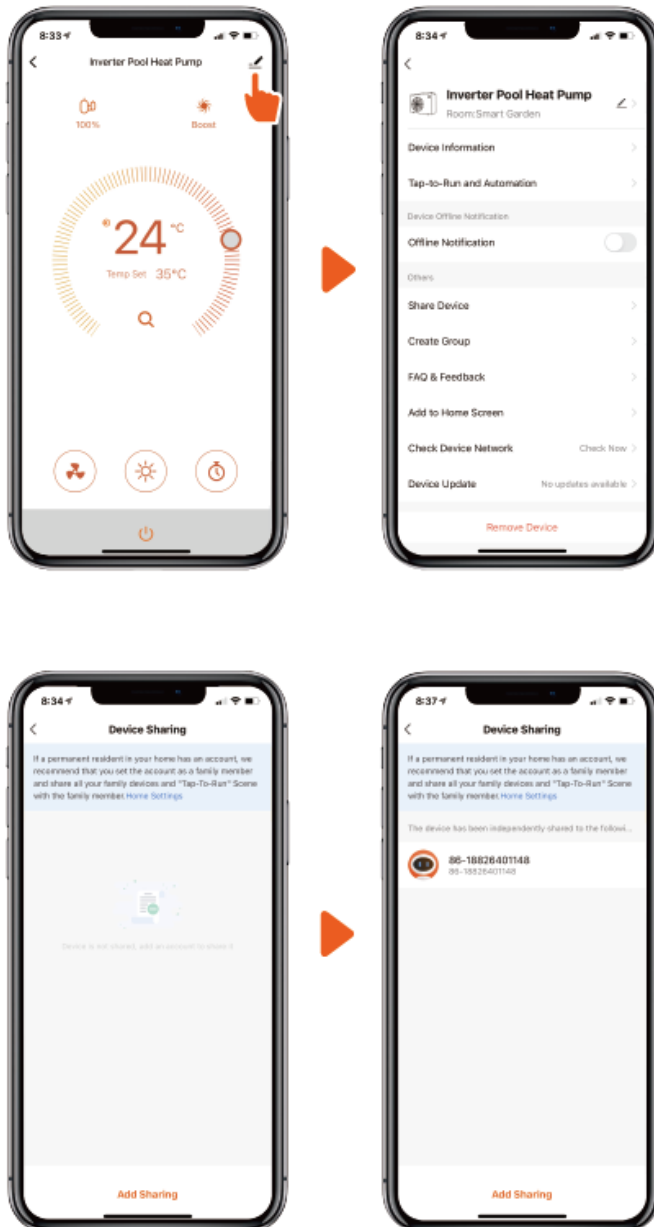

Notice:

1. Weather forecast is just for reference.
2. App is subject to updates without notice.

AQ17CX20-R32-V24-240615AQA1

The company reserves all rights for final explanation.